

System Identification: CIMC-296-01-01-01 Configuration #1

System features: Air Button activated/Electronic keypad(optional) Automatic 30-minute timer, Single Speed Pump, MB Pump, Multi-color Tub Lights

Note: For instructions on setting the Configuration # see "Control Configuration Selection and Setting Guide"

Installation Diagram:

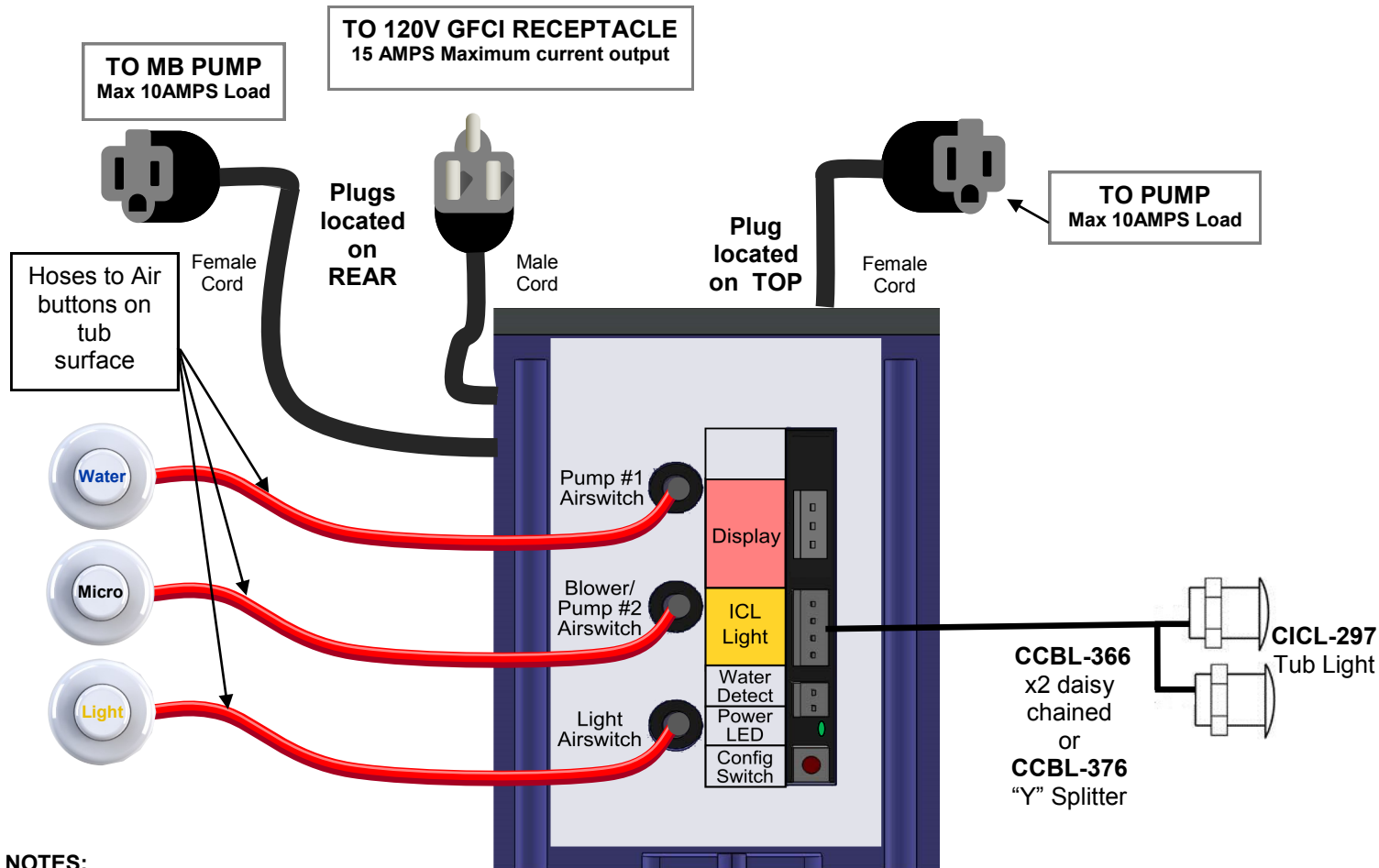

NOTES:

- 1. PUMPS equipped with air switch must be in the "ON" position prior to plugging into the [CIMC-296-01-01-01].**
 2. Surface Heaters cannot be operated without the Electronic Keypad.
 3. Connect cables to ports as shown. Installation may not require the use of all connection ports.
- Failure to connect cables to ports as shown, may damage the control box and its components.**