



# **TOUCHSTONE**

## **Stand Alone**

### **LED Light Control**

**CILA-306-01-01-01**  
**Configuration #2**

## **Owner's Manual**



## Important Safety Instructions

**PLEASE READ CAREFULLY PRIOR TO  
Troubleshooting and Servicing Electrical Equipment**

### Definitions:

**WARNING** (May cause serious injuries or death)

**CAUTION** (May cause property damage)

For information on NuWhirl Instructions, see:  
[www.nuwhirl.com/docs/product-instructions.html](http://www.nuwhirl.com/docs/product-instructions.html)

When installing and using this electrical equipment, basic safety precautions should always be followed, including:

**WARNING:** Keep dry. Replace control if exposed to water, moisture or contamination.

**WARNING:** Use and follow these instructions along with all instructions that have been provided with your whirlpool bathtub in order to fully enjoy the bathtub safely.

**WARNING:** Electronic control system components should be installed as per local and national Electrical Codes, in a location not to be subjected to splashing or flooding. Exposure to water or splashing will void all product certifications and warranties.

There are no user serviceable parts inside. Opening, modifying, or tampering with control system components will void all product certifications and warranties.

**WARNING:** Risk of electric shock. Connect only to a ground type receptacle or power supply junction box protected by a Ground-Fault Circuit Interrupter (GFCI). Contact a qualified electrician if you cannot verify that the power supply is protected by a GFCI. The GFCI should be tested on a routine basis. Consult the GFCI manufacturer's instructions for correct testing and operation.

For electrical connections, see applicable wiring diagram.

See [www.nuwhirl.com/docs/product-instructions.html](http://www.nuwhirl.com/docs/product-instructions.html)

Do not use an extension cord to connect the product to the electric supply; provide a properly located receptacle or junction box.

**WARNING:** Failure to install in strict accordance with each and every instruction above may compromise the system, which may cause injury to persons and/or property.

The tub may be supplied from more than one power source. Before working on any electrical device, make sure all power to the control system is off.

Use this unit only for its intended use as described in this manual. Do not use attachments not recommended by the manufacturer. Any improper installation or misuse of the equipment may result in injury to the user and will void the warranty.

**Save these instructions.**

# **TOUCHSTONE Stand Alone LED Light Control Configuration #2 Owner's Manual**

---

Your whirlpool bathtub has been equipped with a TOUCHSTONE LED Light Control System which transforms the entire bathtub with a wide spectrum of high-intensity colors. Please familiarize yourself with the features and operating instructions below in order to maximize the enjoyment you receive from your bath. These operating instructions should be used in conjunction with the other instructions and warnings provided with your whirlpool bathtub in order to fully understand and safely utilize the bathtub.

## **System Features**

- Air Button and Electronic Keypad Options
- Multicolor Tub Lights

## **Air Button and Electronic Keypad Options**

Your LED Light Control System can be controlled by a dedicated Air Button labeled “Light” or an electronic keypad switch.



**Air Button On/Off**

**OR**

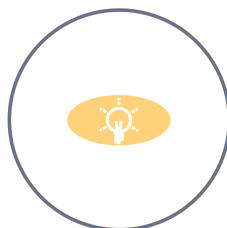

**LED Lights Electronic Keypad On/Off Button**

## Operating Instructions

### Multi-color Tub Light

The Multi-color Tub Light is activated by pressing the “Light” Air Button or electronic keypad at any time.

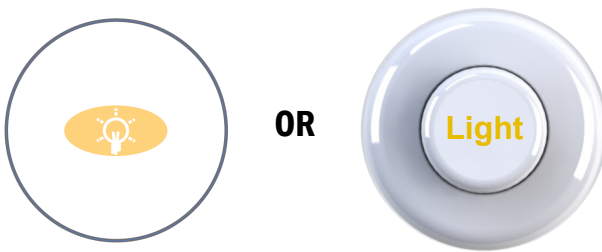

### Rainbow Mode:

The first press will put the light in a “Rainbow” mode, rotating through each of the color variations.



# **TOUCHSTONE Stand Alone LED Light Control Configuration #2 Owner's Manual**

---

## **Single Color Mode:**

Subsequent press-and-release of the “Light” Air Button or keypad will illuminate a single light color in the following order:

**White**

**Blue**

**Aqua**

**Green**

**Yellow**

**Red**

**Magenta**

## **Power off:**

To turn off the Light **press and hold** the “Light” Air Button or keypad at any time.

**System Identification: CILA-306-01-01-01**  
**System features: Stand Alone LED Light Control**

**Note:** For instructions on setting the Configuration Number, see the CILA-306-01-01 *Control Configuration Selection and Setting Guide*.

## Installation Diagram:

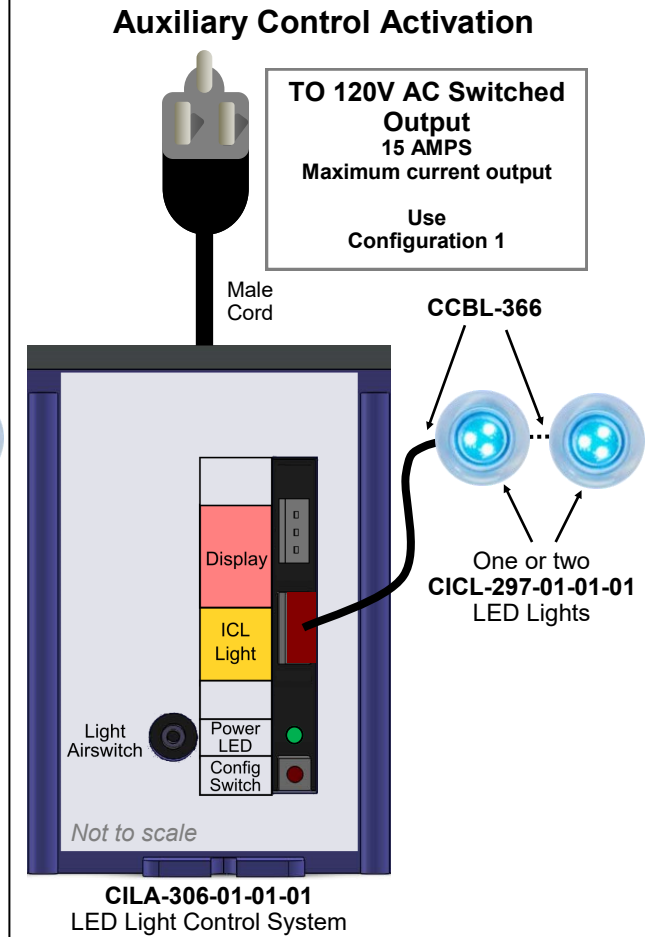
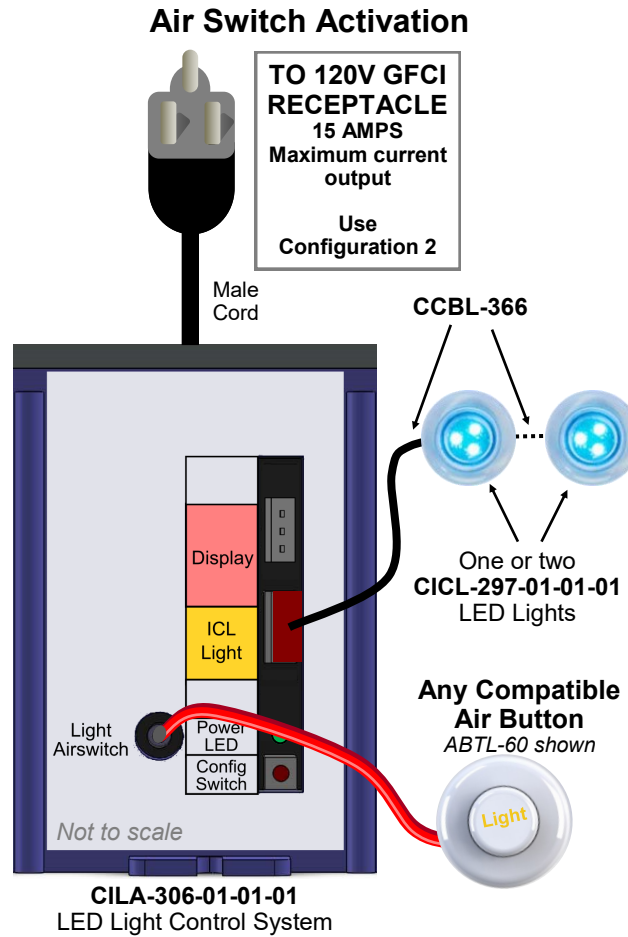
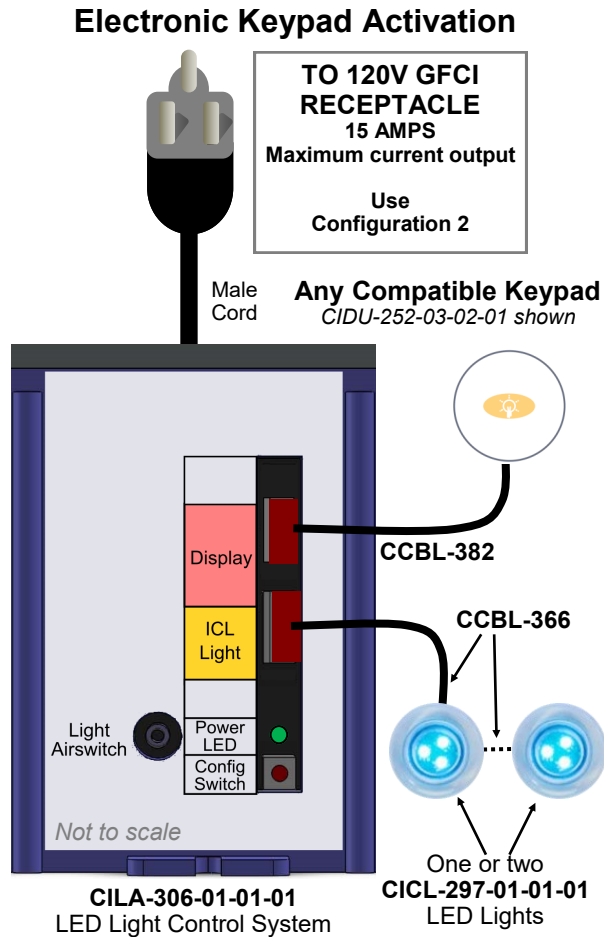

- NOTES:**
- Lights can be activated by an electronic keypad, air switch or auxiliary controller activation. See the NuWhirl Product Guide for all compatible keypad or air switch options.
  - Connect cables to ports as shown. Installation may not require the use of all connection ports.
  - Do not connect any more than two CICL LED lights to the control unit.
- Failure to connect cables to ports as shown, may damage the control box and its components. To be used in conjunction with all other product instructions published by NuWhirl.**

# Retain this manual for future reference

**For your records and future reference  
please fill in data below:**

**Manufacturer:** \_\_\_\_\_

**Model:** \_\_\_\_\_

**Serial:** \_\_\_\_\_

**Date of Installation:** \_\_\_\_\_

